

MITSUBA

SYSTEMS (INDIA) LLP

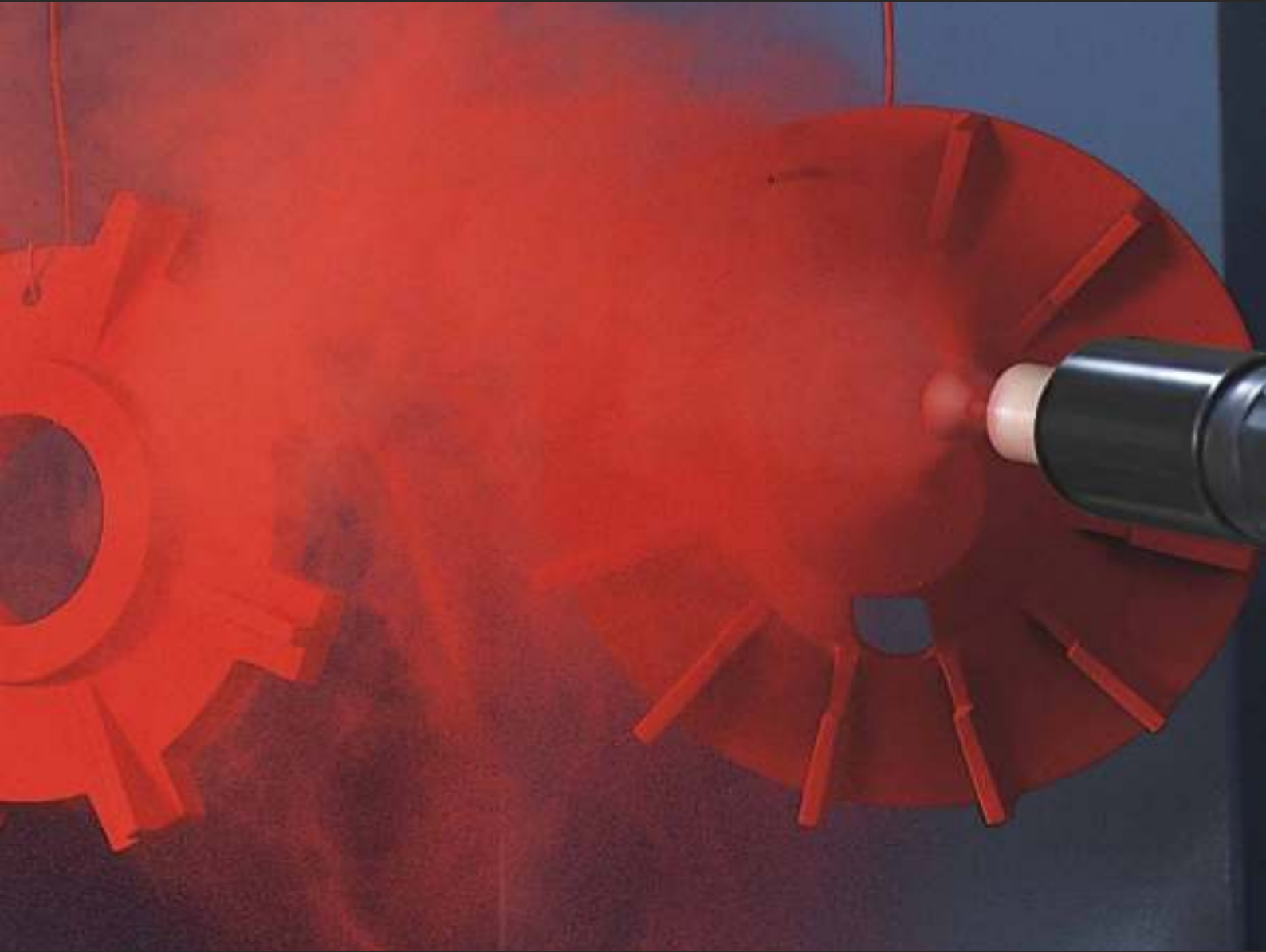

SUPERIOR FINISH
CONSISTENT QUALITY.

MULTISTATIC™ 700 SUPREME



(US PATENT NO. 5678770).

THE CORONA INFINITI™ GUN

OPERATOR-PROOF.
SHOP FLOOR-PROOF.



The all-new Multistatic 700 powder system has advanced features to make the whole powder coating process quick, easy and efficient.

- ⊙ Features a 100 KV built-in electrostatic high voltage generator for enhanced transfer efficiency and reduced wastage.
- ⊙ A powder pathway constructed from wear-resistant material, specially rounded to prevent impact fusion and thus provide a smooth uninterrupted flow.
- ⊙ Coating speed stepped-up by 20%.
- ⊙ Easily maneuverable, well balanced and efficient powder coating gun made from high impact-unbreakable plastic body.
- ⊙ The gun has a patented replaceable power cartridge. (Mitsuba US patent no. 5678770). In the unlikely event of a malfunction, all you do is...



...simply pull the barrel



replace the power cartridge



tighten the nut and you're to go



THE TRIBO GUN

Tribo Gun gives better coating quality & eliminates Faraday's cage effect, thus providing a total solution to meet any coating requirement.



FEATURES

- ③ 3 piece Stainless Steel Round Hopper. Mirror finish for super fast colour change.
- ③ New improved high flow pump with increased ventury life.
- ③ Plug - in plug - out connections.

FAST COLOUR CHANGE WITH SMART BULLETS

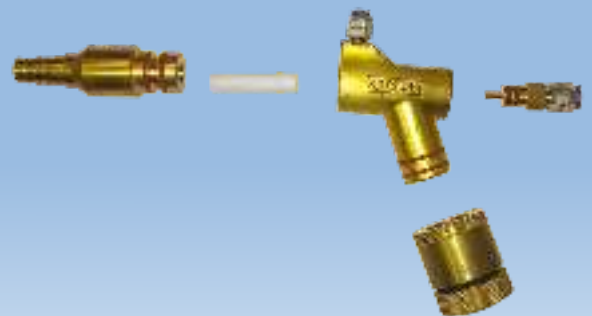

PUMP ASSEMBLY

THE CORONA-CLASSIC ATTACHMENT. FOR A SUPERIOR FINISH.



Produce a substantially superior finish even at higher thickness.

- Can be fitted to both, manual and automatic guns.
- Eliminates wandering charges for disturbance free coating. Reduces 'orange peel effect'.
- Eliminates 'Faraday's Cage Effect', facilitates depth penetration and coating of recessed areas.
- Allows thicker film build-up, if needed.
- Improves coating on welded areas.
- Ideal for re-coating.

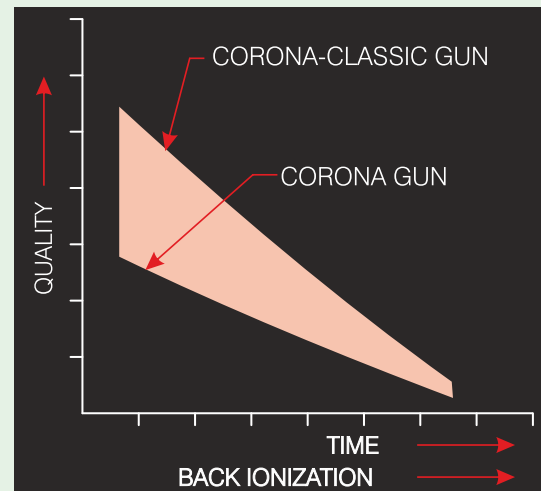

SMART TRACKER SERIES 700

A PERFORMANCE MONITOR WITH
A TRENDESETTING CONCEPT



The new Smart Tracker 700 is a high end diagnostic system which constantly monitors and indicates the performance of every component in the equipment. Even unskilled labour can detect a trouble spot with ease, swiftness and precision. And thanks to the unique plug in-plug out design, the problem can be rectified immediately. In a nutshell, Smart Tracker ensures your system is always in a perfect working condition.



THE TRIBO GUN

Tribo Gun gives better coating quality & eliminates Faraday's cage effect, thus providing a total solution to meet any coating requirement.

LANCE EXTENSIONS

These are ideal for spraying large and deep objects.

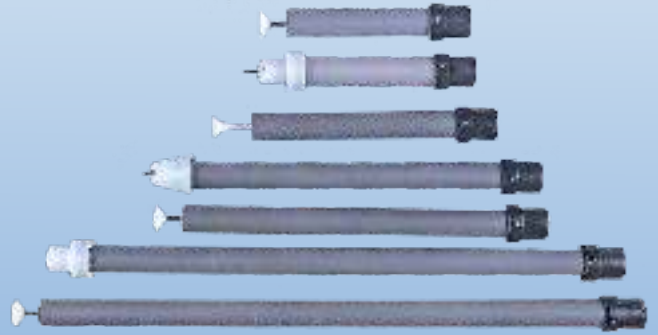

THE POWDER CUP GUN SYSTEM

The cup attachment can be fitted to any standard Infiniti™ gun.

Sampling Cup Attachment



TYPES OF NOZZLES

Mitsuba provides a choice of electrode configurations to permit uniform coverage with minimum over spray and maximum ease.

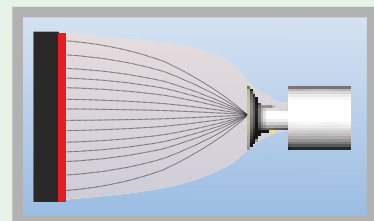

Center electrode system for high transfer efficiency.

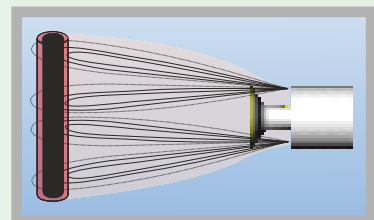

Edge charging system, excellent wrap arounds.

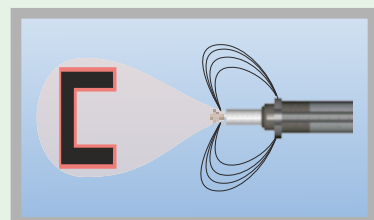

Corona-Classic, complete coverage of contoured pieces.



EFFICIENCY METER

- ⊙ Mitsuba supplies a wide range of meters that ...
- ⊙ Measures Corona Tip high voltage.
- ⊙ Measures levels of charge in a Corona & Tribo Powder cloud.
- ⊙ Measure earthing of the system
- ⊙ Displays both +ve and -ve polarities.

SPRAY GUN ATTACHMENTS

Multifaceted, Innovative, Efficient

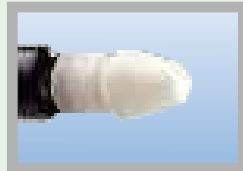

Flat Jet

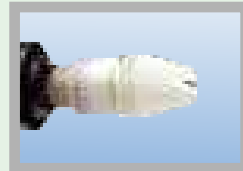

4 Slit Flat Jet

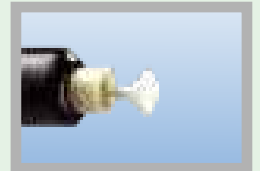

Deflector

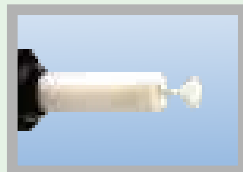

Extended Deflector

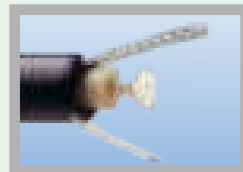

Metallic



Swivel



10 Kgs



15 Kgs



25 Kgs

Different sizes of hoppers are available to suit specific needs, including 2 kg, 10 kg, 15 kg, 25 kg, 50 kg, 100 kg, 150 kg.

FAST COLOUR CHANGE WITH SMART BULLETS



REAL TIME SIEVER

(PATENT No.311783)

**NEW
BREAKTHROUGH
TECHNOLOGY**

- > A Whole New Experience in Ease of Powder Spraying.
- > Optically Brilliant Finishes Piece After Piece.
- > Huge Reduction in Coating Cost.

REALTIMESIEVER (RTS) is the technology of sieving powder while it is being sprayed. It eliminates the complete process of sieving powder separately before reuse.

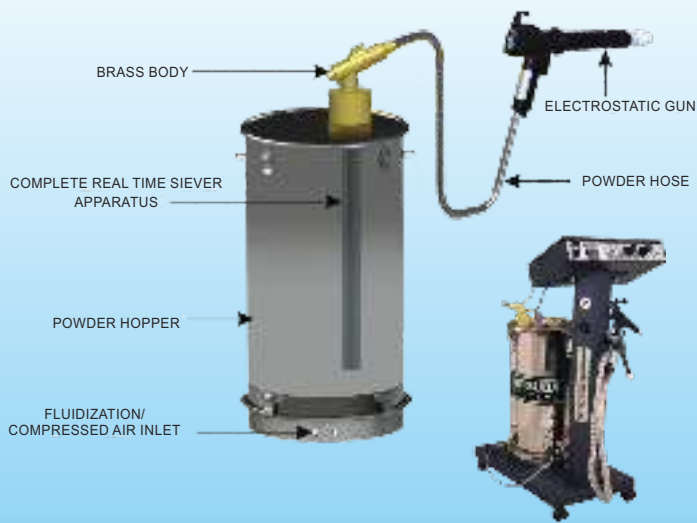

RTS COMPARED TO ANY OTHER GUN

- ⊙ **Saving in Powder Consumption** - with many customers reporting 10% to 12% less powder usage.
- ⊙ **Saving in Process Time** - with elimination of a separate sieving operation and resultant less powder handling.
- ⊙ **Saving in Coating Cost** - with higher transfer efficiency & less overspray, Less rejection, Less wastage & better finish.

REAL TIME SIEVER SETS NEW STANDARDS IN APPLICATION EASE :

Simply fill new or recovered powder in the hopper & spray.

Powder is sieved while it is being sprayed. Distinct individual powder particles from the powder cloud. The resultant powder cloud is extremely uniform.

The finish is substantially superior. Complex shapes are easily coated. Overspray is reduced.



**NORMAL GUN WITHOUT
SIEVING -
MILD
STREAKING**



**NORMAL GUN WITH EXTERNAL
SIEVED POWDER -
ALTERED CLOUD
PATTERN**



**GUN WITH RTS
(Patent No.311783)
CONSISTENT UNIFORM
PATTERN**

SPRAYRIGHT PLUS

WITH REAL TIME SIEVER
(PATENT No.311783)

Worldwide
New

FASTER
COATING

BRILLIANT
FINISH

LESS
OVERSPRAY



SPRAYRIGHT PLUS

WITH REAL TIME SIEVER

(PATENT No.311783)

CONSISTENTLY BRILLIANT FINISHES

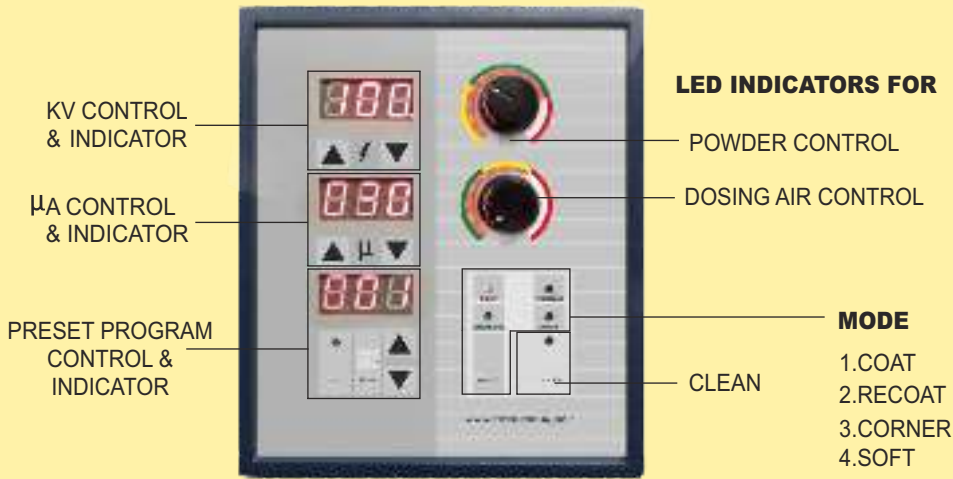

Electro-pneumatic Touch Controls with Digital Display



ALSO AVAILABLE IN MANUAL AND AUTOGUN

Ultimate operating ease with New Ultra Light, Super tough design of spray gun.
Superior transfer efficiency with 100kv at gun tip.

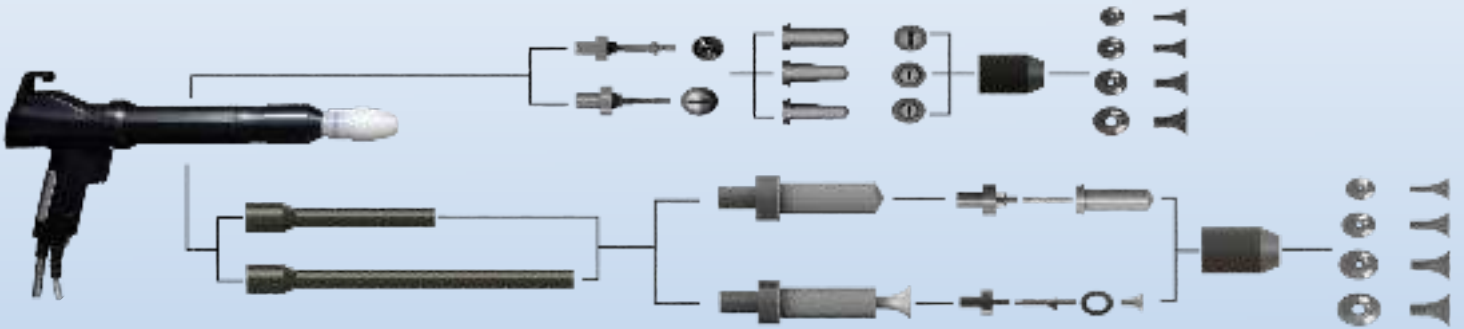

MANUAL

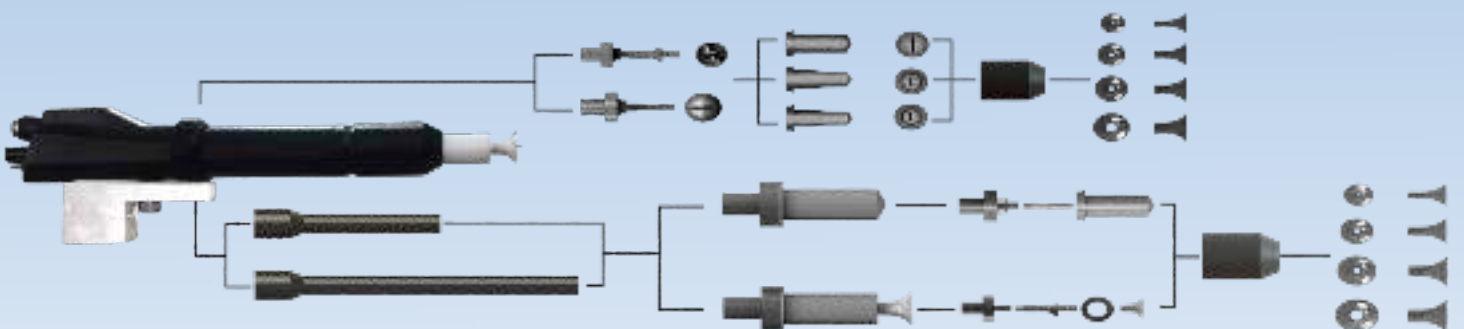

AUTOGUN

SPRAYRIGHT PLUS

WITH REAL TIME SIEVER

(PATENT No.311783)

FEATURES

- ⦿ Sprayright Plus can be preset up to 100 programme's easily.
- ⦿ Unmatched level of ease with touch control for KV, μ A, powder and dosing air.
- ⦿ Powder flow control on the handle of spray gun itself.
- ⦿ 4 Quick mode setting - Coat, Recoat, Corner & Soft
- ⦿ Clean button for auto cleaning of powder pump, hose and gun.



SCOPE OF SUPPLY

- ⦿ Digital control & display of KV, μ A, powder and dosing air on Control Panel mounted on trolley.
- High Efficiency Coat Mode
- Soft Mode
- Recoat Mode
- 100 Preset Programs
- Deep Recess Corner Mode
- ⦿ Integrated 100 KV new design light weight Corona Gun ver 2.
- ⦿ Powder pump with auto cleaning of powder pump, hose and gun & optional Real Time Siever (Patent no.311783)
- ⦿ Stainless Steel Powder Hopper 25 kgs.
- ⦿ Electrosmart powder hose & smart bullets, set of nozzles including Flat Spray & Round Spray, cables & all accessories for start up.

AUTOMATIC POWDER COATING SYSTEMS

SPRAYRIGHT PLUS

FEATURES

- ⊙ Sprayright Plus - 100 programme can be easily preset for instant recall.
- ⊙ Unmatched level of ease with touch control for KV, μ A, powder and dosing air.
- ⊙ 4 Quick mode setting - Coat, Recoat, Corner & Soft.
- ⊙ Clean button for auto cleaning of powder pump, hose and gun.
- ⊙ Modular Concept. Easy to customize.
- ⊙ Corona and Tribo guns operate on same control.
- ⊙ Interlocking available between individual guns and external systems (eg. Part sensing system, Conveyor, Oven).
- ⊙ Meets IP54 standards.

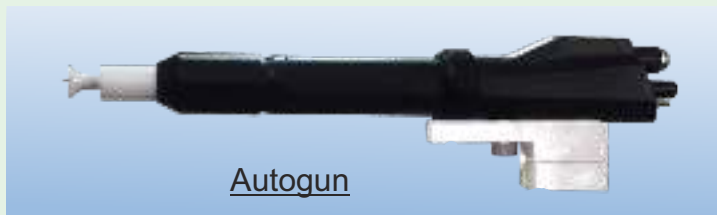

One Touch Panel For Easy Quick Global Control



Touch screen to control a complete set of guns on a single user friendly screen - Just 1 Touch can adjust any or all gun settings depending on the product being coated.

Digital Controller For Individual Gun Control

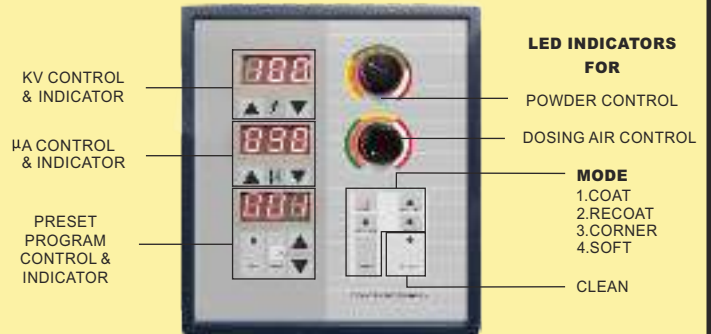

Control panel with digital controls can be preset upto 100 programs. Touch control for KV, μ A, Powder & dosing air, clean button for auto cleaning of powder pump, hose & gun.

AUTOMATIC POWDER COATING SYSTEMS SPRAYRIGHT PLUS

SUMMARY OF BENEFITS:

- Get optically brilliant finishes with consistent uniform film thickness.
- Most suitable for high speed conversed powder coating plant.
- Ergonomic design & Light weight, Powerful new HV Power Cartridge, Wide range of muzzles, nozzles, extensions.
- Centralised powder feed Hopper with Powder pumps.
- Can integrate with Mitsuba Reciprocators, Part sensing system for highest efficiency.

REALTIMESIEVER (RTS) is the technology of sieving powder while it is being sprayed. It eliminates the complete process of sieving powder separately before reuse.

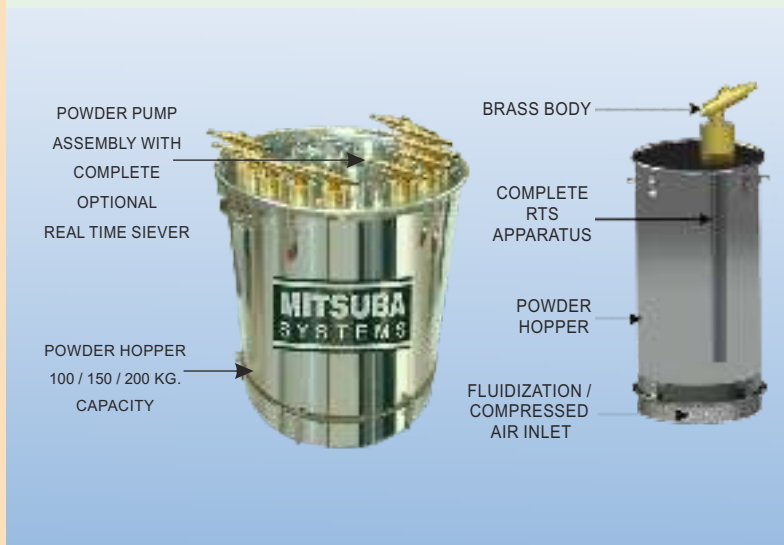

RTS COMPARED TO ANY OTHER GUN

- **Saving in Powder Consumption** - with some customers reporting 10% to 12% Less powder usage.
- **Saving in Process Time** - with elimination of a separate sieving operation and resultant less powder handling.
- **Saving in Coating Cost** - with higher transfer efficiency & less overspray, Less rejection, Less wastage & better finish.



NORMAL GUN WITHOUT
SIEVING -
**MILD
STREAKING**



NORMAL GUN WITH EXTERNAL
SIEVED POWDER -
**ALTERED CLOUD
PATTERN**



GUN WITH RTS
(Patent No.311783)
**CONSISTENT UNIFORM
PATTERN**

MULTISTATIC™ 700 DIPSTICK



The Dipstick™ is a powerful vibrating pump. Just insert the one piece Dipstick™ into any powder box and spray. Suitable for Corona and Tribo guns.

For a quick, efficient and economical colour change :

1. Remove Dipstick™ from the box.
 2. Clean previous colour by blowing air on the Dipstick™.
 3. Insert into another box & spray.
- ⊙ Features an integrated 100KV built-in electrostatic high voltage generator for enhanced transfer efficiency and reduced wastage.
 - ⊙ The gun has a patented replaceable power cartridge. (Mitsuba US patent no. 5678770). In the unlikely event of a malfunction, all you do is



...simply pull the barrel



replace the power cartridge



tighten the nut and you're ready to go



SCOPE OF SUPPLY

- ⊙ A corona powder spray gun with an integrated 100KV electrostatic high voltage generator and patented replaceable power cartridge.
- ⊙ Dual electro-pneumatic control panel with a trendsetting new Smart Tracker. Corona & Tribo gun can be operated from the same panel.
- ⊙ New Dipstick™ and vibratory tray on Trolley.

PNEUMATIC DATA

Optimum Input Pressure : 6 bar
 Max water vapour required: 1.3 g/m³
 Max oil vapour required : 0.1 ppm
 Maximum air consumption: 13.2 m³/hr

ELECTRICAL DATA

Single phase AC : 220V or 230V / 110V
 Safety class: IP 54
 Temp Range: +2°C to 50°C
 Input Voltage: 10V eff
 Output Voltage: 100KV DC
 Output Current : 100µA

FAST COLOUR CHANGE WITH SMART BULLETS



SMART TRACKER



SAMPLING CUP ATTACHMENT



WIDE RANGE OF NOZZLES

MULTISTATIC™ 700 TWIN SERIES



Member of MULTISTATIC CORONA HOPPER SERIES specially designed for online powder coating plant.

- ⊙ Operate two guns simultaneously from one control panel
- ⊙ Features an integrated 100KV built-in electrostatic high voltage generator for enhanced transfer efficiency and reduced wastage.
- ⊙ Individual powder and KV setting for each system
- ⊙ Powder feeding through the same hopper to assure uniformity in powder feeding

The gun has a patented replaceable power cartridge.(Mitsuba US patent no.5678770). In the unlikely event of a malfunction, all you do is



...simply pull the barrel



replace the power cartridge



tighten the nut and you're ready to go

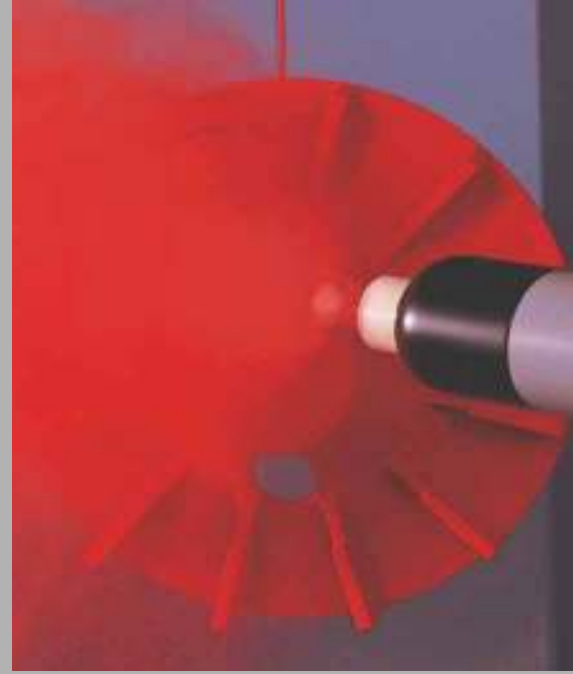

SCOPE OF SUPPLY

- ⊙ A corona powder spray gun with an integrated 100KV electrostatic high voltage generator and patented replaceable power cartridge.
- ⊙ Electro pneumatic Control Panel suitable for 2 Corona OR 2 Tribo Guns
- ⊙ Stainless steel powder hopper 25 Kgs; Powder pump output 0-30 kgs/hr; Trolley; All accessories for startup.

PNEUMATIC DATA

Optimum Input Pressure :6 bar
 Max water vapour required : 1.3 g/m³
 Max oil vapour required : 0.1 ppm
 Maximum air consumption:26.4 m³/hr

ELECTRICAL DATA

Single phase AC : 220V or 230V / 110V
 Safety class: IP 54
 Temp Range:+2°C to 50°C
 Input Voltage:10V eff
 Output Voltage:100KV DC

FAST COLOUR CHANGE WITH SMART BULLETS



TRIBO COMPATIBLE EQUIPMENT



SAMPLING CUP ATTACHMENT



WIDE RANGE OF NOZZLES

SPRAYRIGHT™ 700 PREMIUM



ADVANTAGES

- ⊙ Integrated 100KV built in electrostatic high voltage generator
- ⊙ Specially rounded pathway to prevent impact fusion ensures smoother flow.
- ⊙ Dual gun usage -Corona or Tribo
- ⊙ New compact control panel of IP 54 Standards promotes easier maintenance.
- ⊙ 3 piece stainless steel powder hopper allows for fast cleaning

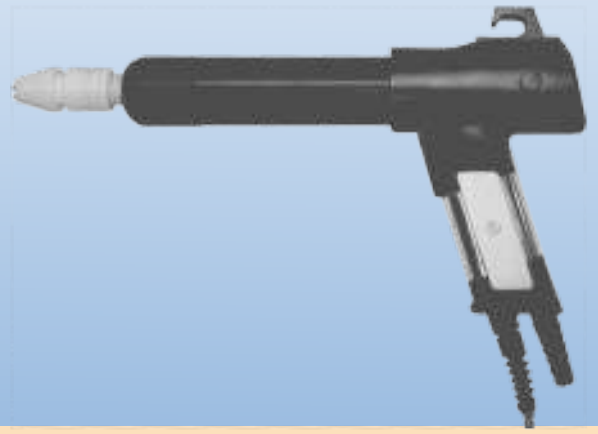

MOULDED CORONA GUN

FAST COLOUR CHANGE WITH SMART BULLETS



SCOPE OF SUPPLY

- ⊙ A Corona Powder Spray Gun with integrated 100 KV Electrostatic high voltage generator
- ⊙ Dual electro-pneumatic control panel suitable for both Corona and Tribo Guns
- ⊙ Stainless Steel 10KG hopper with powder pump output of 0-30 Kg/Hr
- ⊙ Trolley with all other accessories required for start up

TRIB



TRIBO CONTROL UNIT

FOR MANUAL & AUTOMATIC GUNS



- ⊙ Allows individual control of powder flowrate and powder diffusion.
- ⊙ Charge Display Module monitors Tribo charge current.



FEATURES

- ⊙ 3 piece Stainless Steel Round Hopper. Mirror finish for super fast colour change.
- ⊙ New improved high flow pump with increased ventury life.
- ⊙ Plug - in plug - out connections.



PUMP ASSEMBLY

TRIBO PRINCIPLE

A new positive powder charging technique without high tension generators:

It is a self exciting ion generator that charges individual powder particles without generating field lines or ionizing air. Faraday cage is eliminated, resulting in perfect finishes even on the most complex shapes.

Electrostatic friction charging ensures a uniform spray and eliminates the Faraday Cage effect.

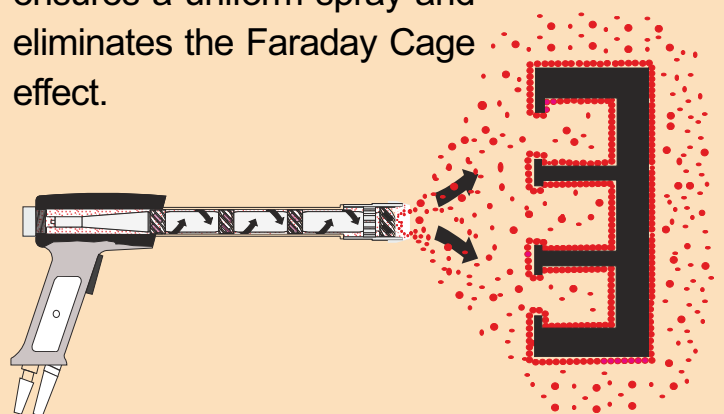

SPRAYRIGHT TABLE-TOP SERIES - EXPERT

Suitable for both Corona & Tribo Guns

- ⊙ A small handy Table-Top System accommodating a complete powder spray system suitable for both Corona & tribo Guns.
- ⊙ Ideal for big as well as small production runs, sampling, colour matching prior to powder batch productions and powder trials at customer's premises.
- ⊙ Can be converted to a full fledged Production model by the addition of below mentioned optional accessories
- ⊙ For Extreme small trails powder cup attachments can be utilized with this system(need to be purchased at Extra cost)

SPECIFICATIONS

Size	: 21" x 11" x 18" (533mmx279mm x457mm)
weight	:2kgs(26pounds)
Input voltage	: Selectable 220V/230V/110V 50/60 Hz, 50VA
Max Input pressure	: 10 bar
Optimum Input pressure:	6 bar



SCOPE OF SUPPLY

- ⊙ 100 Kv Corona Gun with panel
- ⊙ Powder Spray Control Panel.
- ⊙ Round Spray Muzzle (25mm, 18mm, 15mm) Deflectors
- ⊙ Flat Spray Muzzle.
- ⊙ Powder Hopper 2kg with pump.
- ⊙ Accessories.
- ⊙ Tribo Gun(optional at Extra cost).

Optional Accessories to be specially Ordered:



CONTROL PANEL



TRIBO GUN



CORONA GUN



HOPPER



PUMP

Expansion Accessories can be added at extra cost to convert this system into a full scale industrial production Model.

SPRAYRIGHT TABLE-TOP SERIES - PRO

Suitable for both Corona & Tribo Guns

- Perfect entry level system for end users having small production runs.
- A small handy Table-Top System accommodating a complete powder spray system suitable for both Corona & tribo Guns.
- Ideal For the small jobber & serious hobbyist.
- Excellent for powder trials

SPECIFICATIONS

Size	: 18" x 11" x 18" (457mm x 279 mmx 457mm)
Weight	: 8 Kgs (16 pounds)
Input voltage	: Selectable 220V/230V/110V 50/60 Hz, 50VA
Max Input pressure	: 7 bar
Optimum Input pressure:	6 bar



SCOPE OF SUPPLY

- A Corona Gun with integrated 100 KV HV generator.
- Powder Spray "Pro" Control Panel.
- Round Spray Muzzle (25 mm, 18 mm, 15mm) Deflectors
- Flat Spray Muzzle.
- Powder Hopper 2kg with pump.
- Accessories.
- Tribo Gun(optional at Extra cost).



CONTROL PANEL



TRIBO GUN



CORONA GUN



HOPPER



THE COMPLETE PORTABLE SYSTEM

FOR LAB & AT SITE USAGE

- ⊙ A small handy case accommodates a complete powder spray system including both Corona and Tribo Guns.
- ⊙ Ideal for big as well as small production runs, sampling, colour matching prior to powder batch productions and powder trials at customer's premises.
- ⊙ The Lightweight aluminum bag provides a solid and safe packing and is suitable for transportation by air or car for all site trials.

SPECIFICATIONS

Briefcase size : 20" x 16" x 10"
(525mm x 410mm
x 260mm)

Briefcase weight : 17kgs (22pounds)

Input voltage : Selectable
220V / 230V / 110V
50/60 Hz, 50VA

Max Input pressure : 10 bar

Optimum Input
pressure : 6 bar



SCOPE OF SUPPLY

- ⊙ 100 KV Corona Gun with panel
- ⊙ Tribo Gun (Optional)
- ⊙ 2kg hopper with pump
- ⊙ Fluidizing powder cup.
- ⊙ Gravity powder cup.
- ⊙ Round Spray Muzzle (24 mm, 18 mm),
- ⊙ Flat Spray Muzzle & Metallic Muzzle
- ⊙ Corona Classic Attachment



PORTABLE CASE



TRIBO GUN



CORONA GUN



FLUIDISING CUP

POWDER COATING GUN

FOR PTFE, PVDF, NYLON, HALAR[®], PFA & SPECIAL POWDERS



Mitsuba offers unique powder coating gun for PTFE, PVDF, Nylon, Halar[®], PFA & special powders. As these powders have their own coating challenges and charging characteristics, regular Powder coating guns do not deliver an optimum result. Specially designed powder coating gun are needed as these powders are very expensive & also difficult to handle.

- ⦿ 100 KV corona gun with negative polarity.
- ⦿ Single control panel to operate both the guns.
- ⦿ Lower initial cost.
- ⦿ 5kg and 10Kg hopper saves expensive powders.
- ⦿ Sampling cup for small batch runs.

FAST COLOUR CHANGE GUN

WORLDWIDE FAVOURITE AMONGST POWDER MANUFACTURERS

5 UNBEATABLE ADVANTAGES

- ⦿ Extra fast colour change in seconds.
- ⦿ Used in labs for testing powder & resin.
- ⦿ Spray very small quantities of powder.
- ⦿ Suitable for all powder types like Epoxy, Polyethylene, Hybrid, Polyurethane, etc. Also sprays Metallic powder.
- ⦿ Can operate both Corona as well as Tribo charging guns.

SPECIFICATIONS

Size	: 27 x 9.5 x4.5cm
Weight	: 8 kgs
Input voltage	:Selectable 220V/230V/110V 50/60Hz, 50VA
Max Input pressure	: 7 bar



SCOPE OF SUPPLY

- ⦿ 100KV Integrated Moulded Corona Gun
- ⦿ Electro pneumatic control panel having Smart Tracker Peak Performance Monitor & suitable for Corona & Tribo Guns
- ⦿ 100gms Sampling Cup
- ⦿ Flat spray muzzle and nozzle
- ⦿ Metallic Muzzle
- ⦿ All accessories for startup



CONTROL PANEL



TRIBO GUN



CORONA GUN

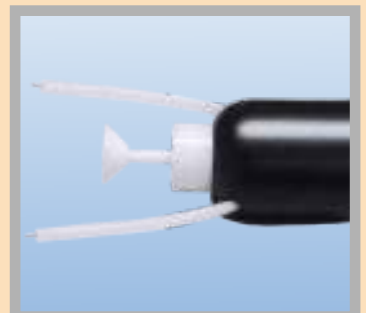

METALLIC MUZZLE

CORONA POWDER SPRAY SYSTEM FOR FPI



Cracks clearly visible
after fluorescent spray

Spraying developer powder is one of the most crucial steps in Fluorescent Penetrant Inspection process. Mitsuba has mastered the art and science of electrostatic spray of developer powder.

BENEFITS

- Special powder feeding system for developer powder
- Entire range of nozzles to select from for highest transfer efficiency.
- A most easily maneuverable, well balanced and efficient powder gun constructed from wear-resistant material, specially rounded to prevent impact fusion and thus provide a smooth uninterrupted flow.

SCOPE OF SUPPLY

A corona powder spray gun with an integrated 100KV electrostatic high voltage generator and patented replaceable power cartridge specially made for the FPI process

Dual electro- pneumatic control panel with a trendsetting new Smart Tracker. Corona & Tribo guns can be alternately operated on the same panel

Stainless steel powder hopper 25 Kgs with Stirrer, Trolley, All accessories for startup

PNEUMATIC DATA

Optimum Input Pressure : 6 bar
Max water vapour required: 1.3 g/m³
Max oil vapour required : 0.1 ppm
Maximum air consumption : 13.2 m³/hr

ELECTRICAL DATA

Single phase AC : 220V or 230V / 110V
Safety class : Ip54
Temp Range : +2°C to 50°C
Input Voltage : 10V eff
Output Voltage : 100KV DC
Output Current : 100μA



SMART TRACKER



STIRRER HOPPER



WIDE RANGE OF NOZZLES

MULTISTATIC 700 BN

THE BORON NITRIDE COATING APPLICATION TO ENSURE
QUALITY & EFFICIENCY FOR ALUMINIUM EXTRUSION PROCESS

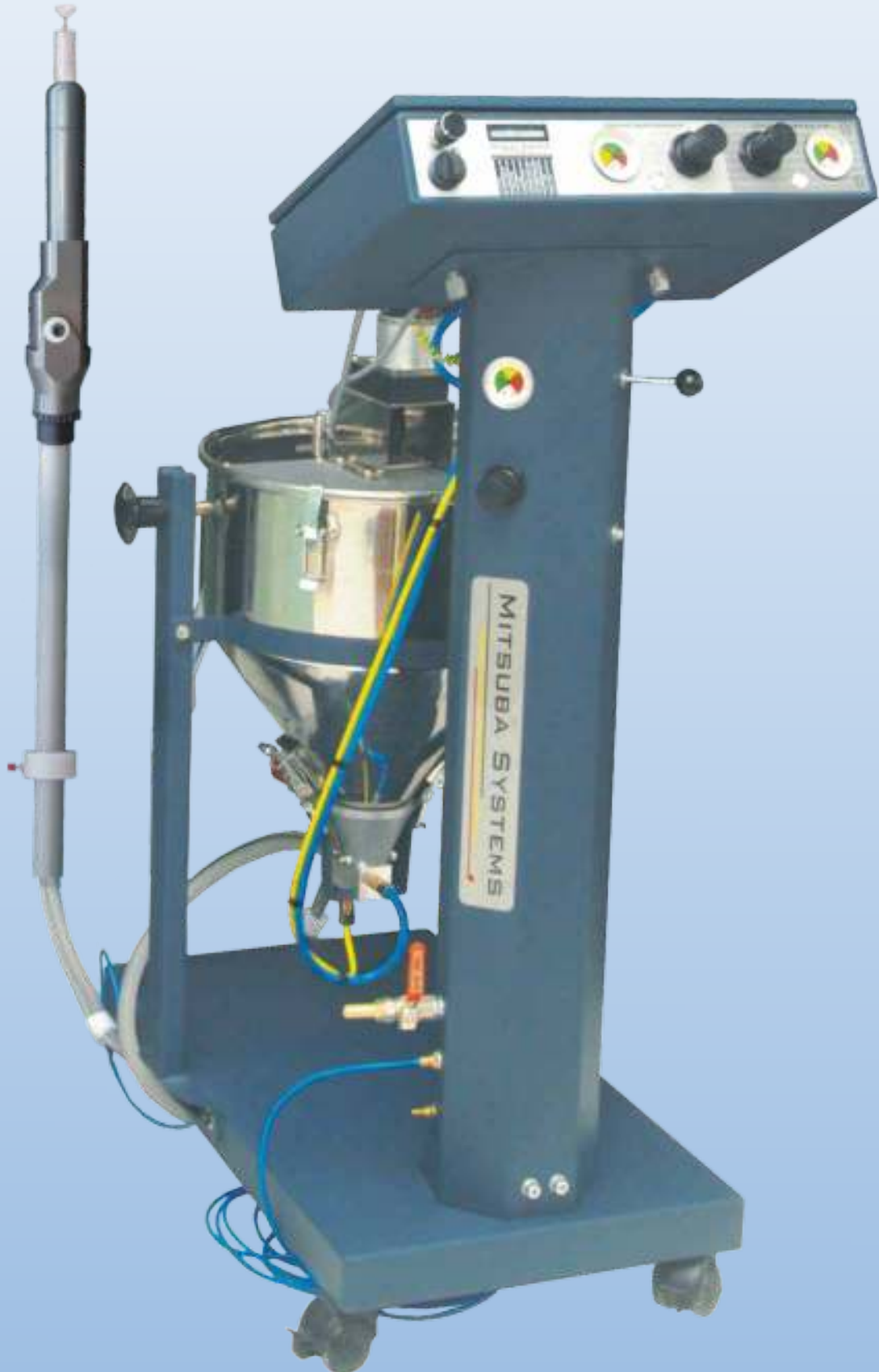

MULTISTATIC 700 BN

FOR AN OUTSTANDING FINISH ON EXTRUDED ALUMINIUM

- ⊙ Integrated 100KV high voltage generator for reduced wastage, high transfer efficiency.
- ⊙ Easily maneuverable, well balanced and efficient powder gun constructed from wear-resistant material, specially rounded to prevent impact fusion for smooth flow.
- ⊙ Easily applies Boron Nitride Lubricant between dummy block and billet. Application is dry, without any carrier.

ADVANTAGES

- ⊙ Outstanding release properties and lubrication
- ⊙ Improved safety and cleanliness : no open flames
- ⊙ Reduced coating frequency : shorter down times-increased productivity
- ⊙ Not harmful to health

SCOPE OF SUPPLY

- ⊙ Integrated 100KV high voltage corona sprayer.
- ⊙ Electro-pneumatic control panel with a trendsetting new SmartTracker.
- ⊙ Conical Stainless steel hopper 10 Kgs for uniform application and even spray. Powder pump (0-30 kgs/hr); Trolley; All accessories for startup.

AUTOMATED BILLET COATING SYSTEM

- ⊙ Automatically coats leading edge of Billet.
- ⊙ Accepts Signal of billet in front of Fixed Gun.
- ⊙ User set table timing system for coating parameter setting.



PNEUMATIC DATA

Optimum Input Pressure	: 6 bar
Max water vapour required	: 1.3 g/m ³
Max oil vapour required	: 0.1 ppm
Maximum air consumption	: 13.2 m ³ /hr

ELECTRICAL DATA

Single phase AC	: 220V or 230V / 110V
Safety class	: IP 54
Temp Range	: +2°C to 50°C
Input Voltage	: 10V eff
Output Voltage	: 100KV DC
Output Current	: 100 A

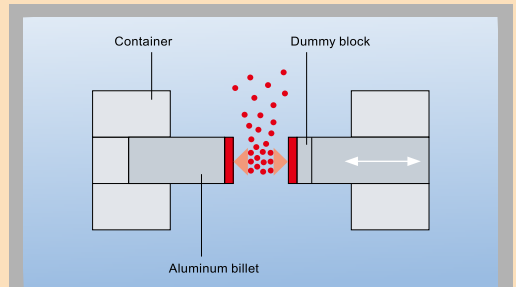

Automatic Boron Nitride dry powder coating of aluminium billets without human intervention

FBE COATING SPRAY SYSTEM

SPECIALLY DESIGNED FOR PIPE AND RE-BAR COATING



With the increasing need to provide FBE coating of 500 to 1000 micron in a single layer coating method, pipe coaters now install High Flow Gun or combination of High Flow and Standard Flow Gun in their plant.

Mitsuba is the first company in the world to produce the integrated Gun with High Flow Capacity.



STANDARD FLOW Infiniti™ GUN
(U.S. Patent No. 5678770)
CAPACITY 0 - 30 Kg/hr.



High Flow GUN
CAPACITY 0 - 50 Kg/hr.



FBE COATING SPRAY SYSTEM

SPECIALLY DESIGNED FOR PIPE AND RE-BAR COATING



FEATURES

- ⦿ Specifically designed for uniform & rapid spray of FBE powder on preheated pipe sections.
- ⦿ **High Flow Gun** allows upto 50 kg/hr of FBE powder flow & thus suitable for new generation pipe coating requiring film thickness of 500 to 1000 microns. (Suitable for Dual FBE).
- ⦿ **Standard Flow Gun** allows powder flow upto 0 to 30 Kg/hr (Suitable for Re-bar and Conventional 3 layer pipe coating).
- ⦿ Integrated 100 KV - No HV Cable - Reduced Maintenance.
- ⦿ Control Panel with Performance Monitor.



AUTOMATIC POWDER COATING EQUIPMENT

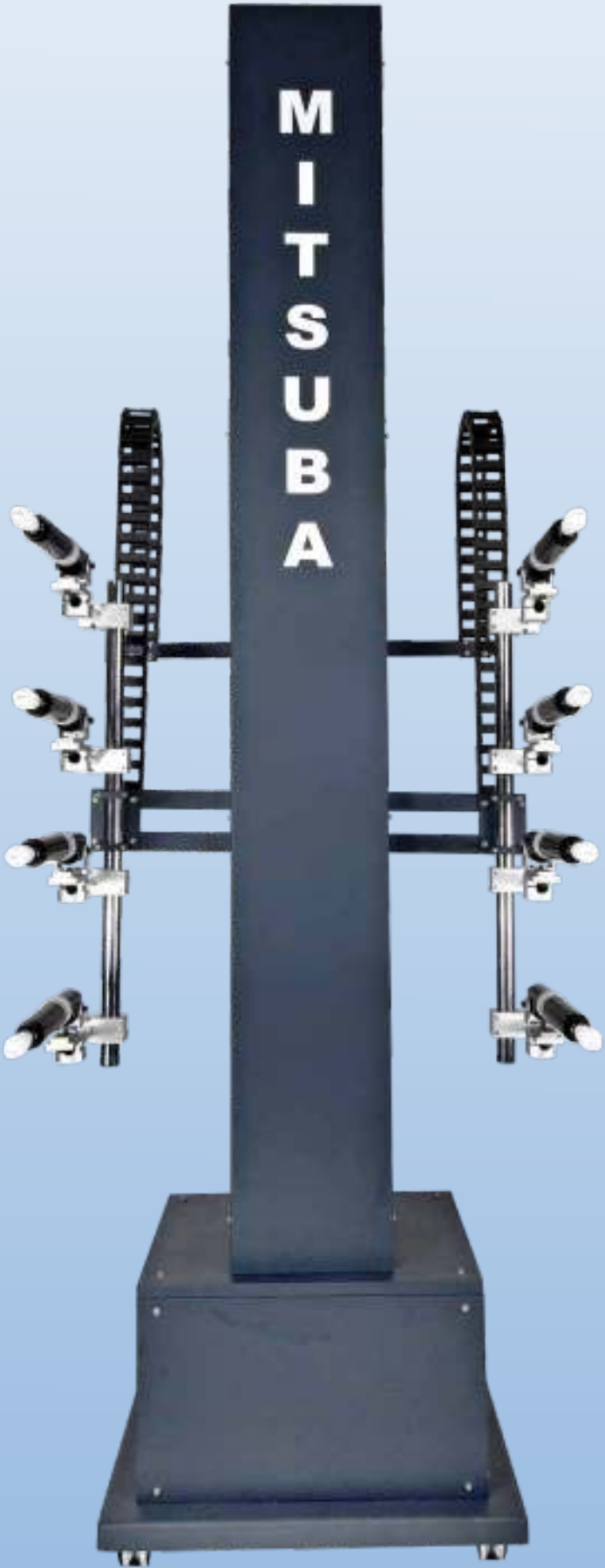

AUTOMATIC POWDER COATING EQUIPMENT

SUMMARY OF BENEFITS:

- ⦿ Get a perfect finish with consistent uniform film thickness.
- ⦿ Most suitable for high speed conversed powder coating plant.
- ⦿ 100 KV gun with Patented Infiniti™ technology (US Patent No. 5678770) protects your gun against any failure. NO BREAKDOWN! NO EXPENSIVE REPAIRS!
- ⦿ Control panel with smart tracker, performance monitor, self diagnosing system gives complete control in your hands.
- ⦿ Centralized powder feed Hopper with Powder pumps.
- ⦿ Can integrate with Mitsuba Reciprocator, Spray police for highest efficiency.



ELECTRO MECHANICAL OSCILLATOR

FEATURES

Multiple guns are mounted on arms extending from the carriage, which are capable of performing same or various motions.

There is a facility to attach fixed guns which can be angled to access difficult coating areas.

The carriage is programmed to move the vertical mounting bar at variable stroke and speeds.

The carriage moves up and down through an AC geared motor and is supported by a very sturdy frame structure. The entire Oscillator is mounted on wheels to facilitate easy movement during colour change.



SPECIFICATIONS

STROKE SPEED: 0 - 28 Cycles / Minute
(infinitely Selectable)

STROKE: 100 mm min / 300 mm Max of
Vertical Bar

ANGLE OF SWING: Adjustable upto 90 deg.

MAX NO.OF GUNS: To Suit Application

CONTROL: Variable Frequency

DRIVE MOTOR: Geared ½ hp. Ac Motor

INPUT VOLTAGE: Single Phase 230 Vac
(Other Voltages on Request)

POWER: 0.37 KW (1/2 hp)



SPEED CONTROL

Speed of the moving guns can be varied between 0 to 28 cycles/min by turning the speed adjuster knob. This step in turn gives a signal to an advanced A.C. frequency drive to achieve the desired speed.

STROKE CONTROL

Stroke of each gun can be varied by changing the gun mounting rod distance from fulcrum. By increasing the distance of the gun from the fulcrum, the resultant arc (movement height) of each gun can be increased.

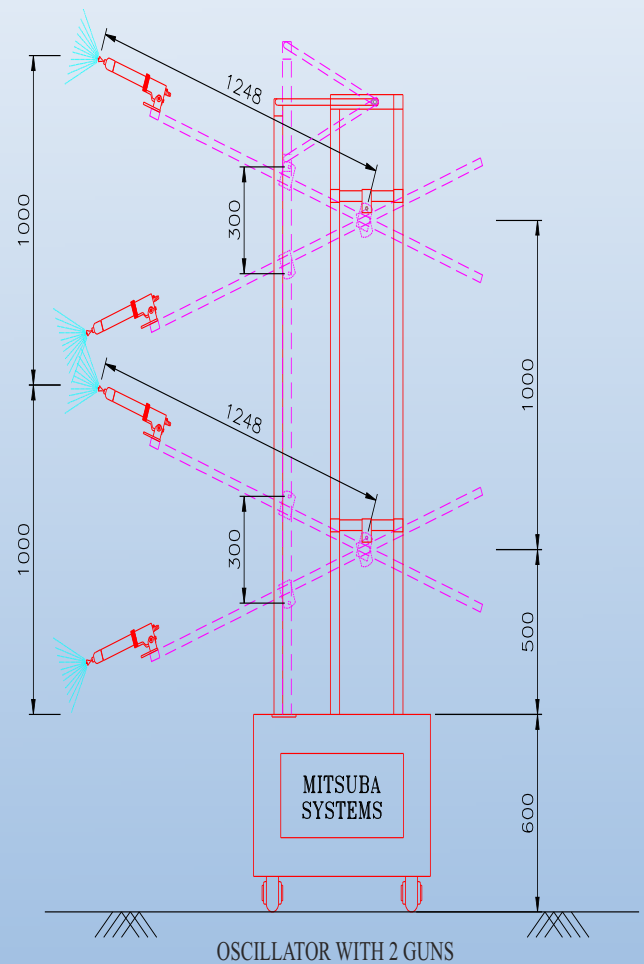

Fulcrum - 1250mm Individual Gun Stroke - 1000 mm
Total Stroke - 2000mm No. Of Guns - 2



This larger gun stroke coupled with lesser number of guns are an ideal combination for conveyor line speeds of about 0.6mtr/min to About 1.5 mtr/min.

This lesser gun stroke coupled with higher number of guns are an ideal combination for conveyor line speeds greater then 1.5mtr/min to about 3.0mtr/min.

EXAMPLE

Fulcrum to gun distance = 1250mm, Stroke = 1000mm.

Fulcrum to gun distance = 625mm, Stroke = 500mm.

Fulcrum to gun distance = 2500mm, Stroke = 2000mm.

In brief, to increase stroke, increase fulcrum to gun distance & vice-versa. This is easily achieved by simply pulling the gun holding rod.

ELECTRO-MECHANICAL RECIPROCATOR XL-SERIES

Mitsuba Electro-Mechanical Reciprocator possesses the capability to vary the speed & stroke to suit your requirements. The control panel incorporates a user friendly touch screen for extreme simplicity of operations even by unskilled labour.

The Reciprocator is electrically driven via an AC geared motor, giving gentle and distinct motion thus ensuring the best possible coating result.

The movement of the carriage is controlled by a most up to date AC frequency drive and advanced digital controller to achieve the desired stroke and speed.

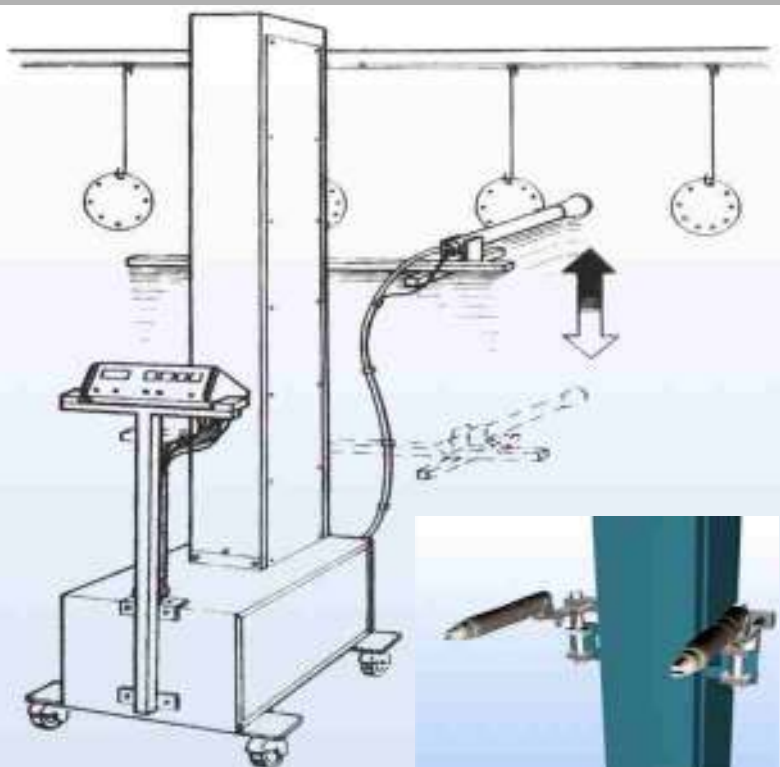

1. Increased Simplicity-
Advanced touch screen digital control.
2. Maximum reliability with ease-
& Simplicity of design. The screen itself guides
the user on what to touch so no formal
usage training is needed.
Improved finished –
3. Smooth Movement during traversing
and change of direction.
4. Quick Job Change –
Pre-programmable preset points for
automatic selection of stroke and
speed.

PART LIST

1. STROKE CARRIAGE
2. BELT
3. COUNTERBALANCE TROLLEY
4. GEAR MOTOR
5. SPROCKET
6. GUN
7. CARRIAGE GUIDE PILLAR
8. RECIPROCATOR BASE
9. CASTOR WHEELS

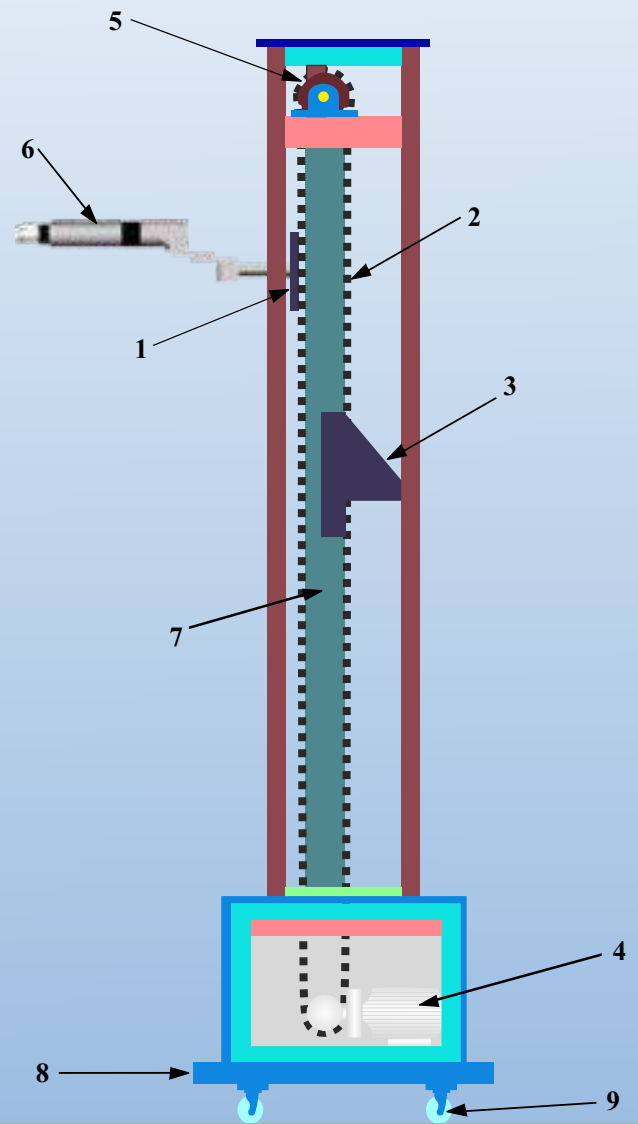

TOUCH SCREEN CONTROL



SPECIFICATIONS

- ⊙ Speed : 0-30 Mt./Min (Infinitely Selectable)
- ⊙ Minimum Stroke : 100 mm
- ⊙ Standard Stroke Length : 1200 mm, 1500 mm, 1800 mm, 2000 mm, 2500 mm.

CONTROL

- ⊙ Analog : Operator sets both speed and stroke separately for each type of job.
- ⊙ Digital : New touch screen Graphic Display & control with (99) Pre-Set programmable points.
- ⊙ Multi Speed : Three multi speed settings selectable along the main stroke. Speed can be different in various lengths of the same stroke.
- ⊙ Can be integrated with “Spray Police” powder optimization, so gun spray is triggered only during presence of work piece.

SPRAY POLICE

BEHOLD THE POWER OF VISION

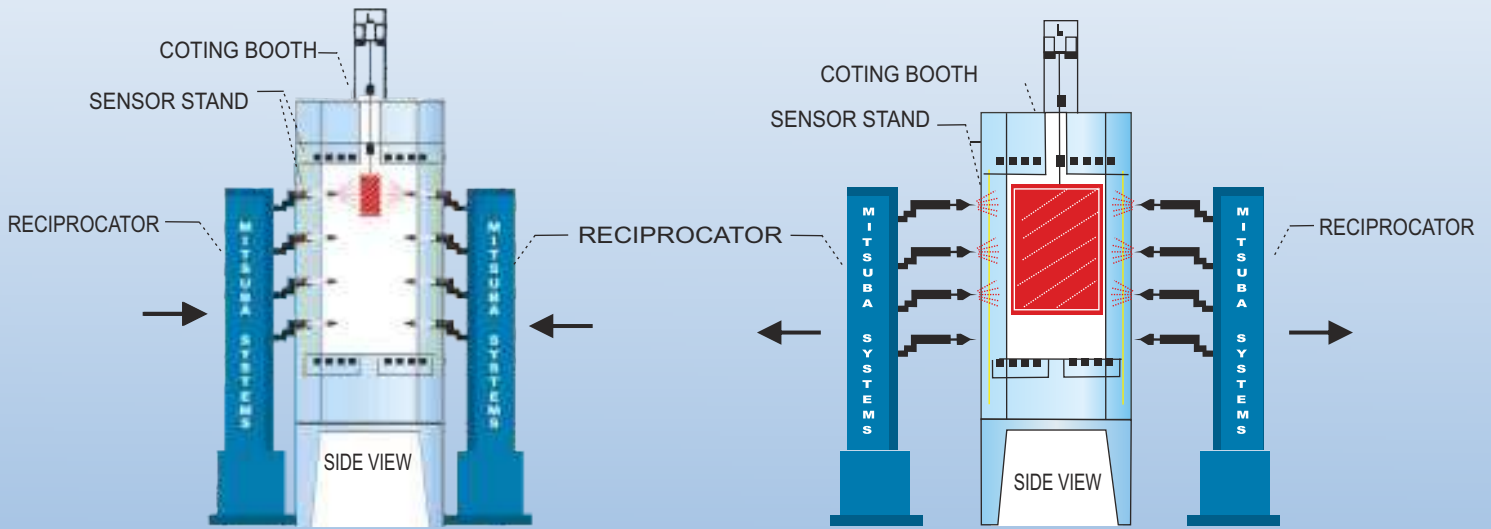

Guns move closer when narrow objects are coated

Guns move away when wider objects are coated

New generation gun triggering system.

- ⊙ Automatically maintains gun to part distance and turns off extra spray guns depending upon product shape and size.
- ⊙ Switches off powder from auto guns when there is no product in front of the guns.
- ⊙ Reduces powder wastage and increases profitability.
- ⊙ Easy touch screen controls.

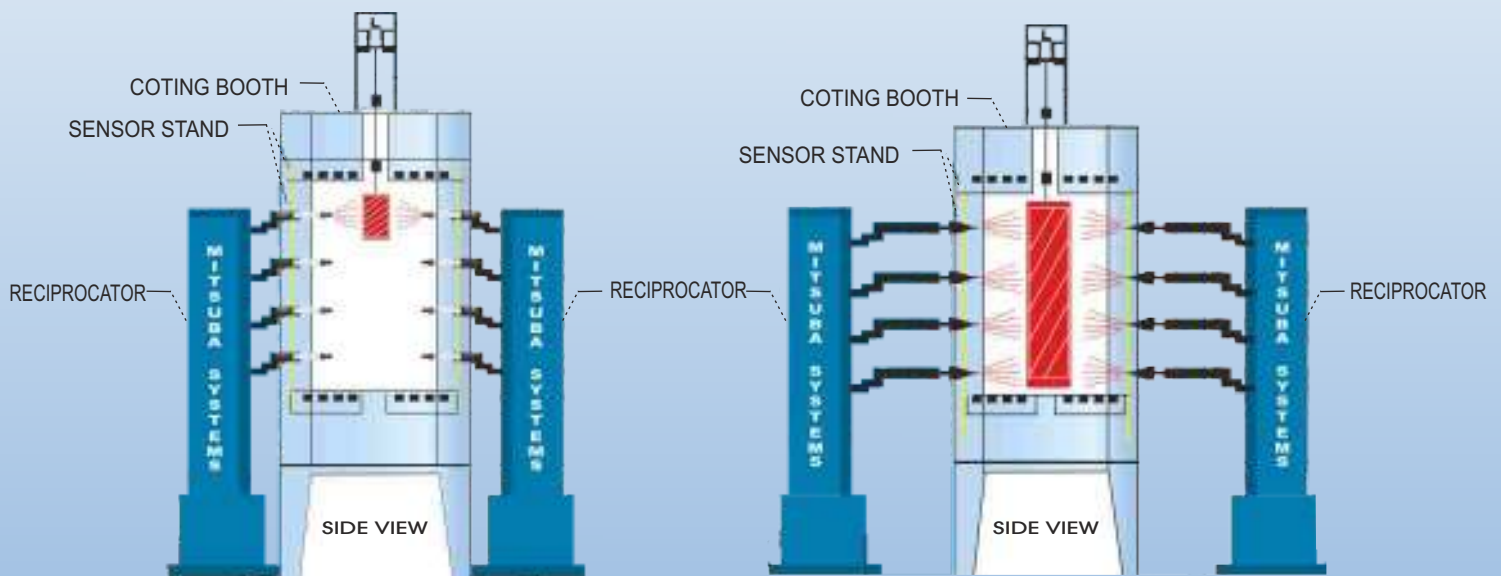

Less guns trigger for smaller object

More guns trigger for larger object

UNI SINGLE CYCLONE SERIES

• STAINLESS-STEEL • 97% EFFICIENCY • SUPERFAST COLOR CHANGE

1, 2, 3 and you are ready for a new color



Unclamp and slide.



Air blow cleaning.



Slide, reclamp & ready to go....



Uni cyclone Recovery is ideally suitable for big automatic plants where the quantity of powder to be sprayed and recovered is high.

SUMMARY OF BENEFITS :

- ⊙ Low Initial cost.
- ⊙ Fast colour change.
- ⊙ Modular construction makes shipping and installation easy.
- ⊙ Can be integrated with automatic powder management system for recycling of over spray.

UNI SINGLE CYCLONE SERIES

• STAINLESS-STEEL • 97% EFFICIENCY • SUPERFAST COLOR CHANGE

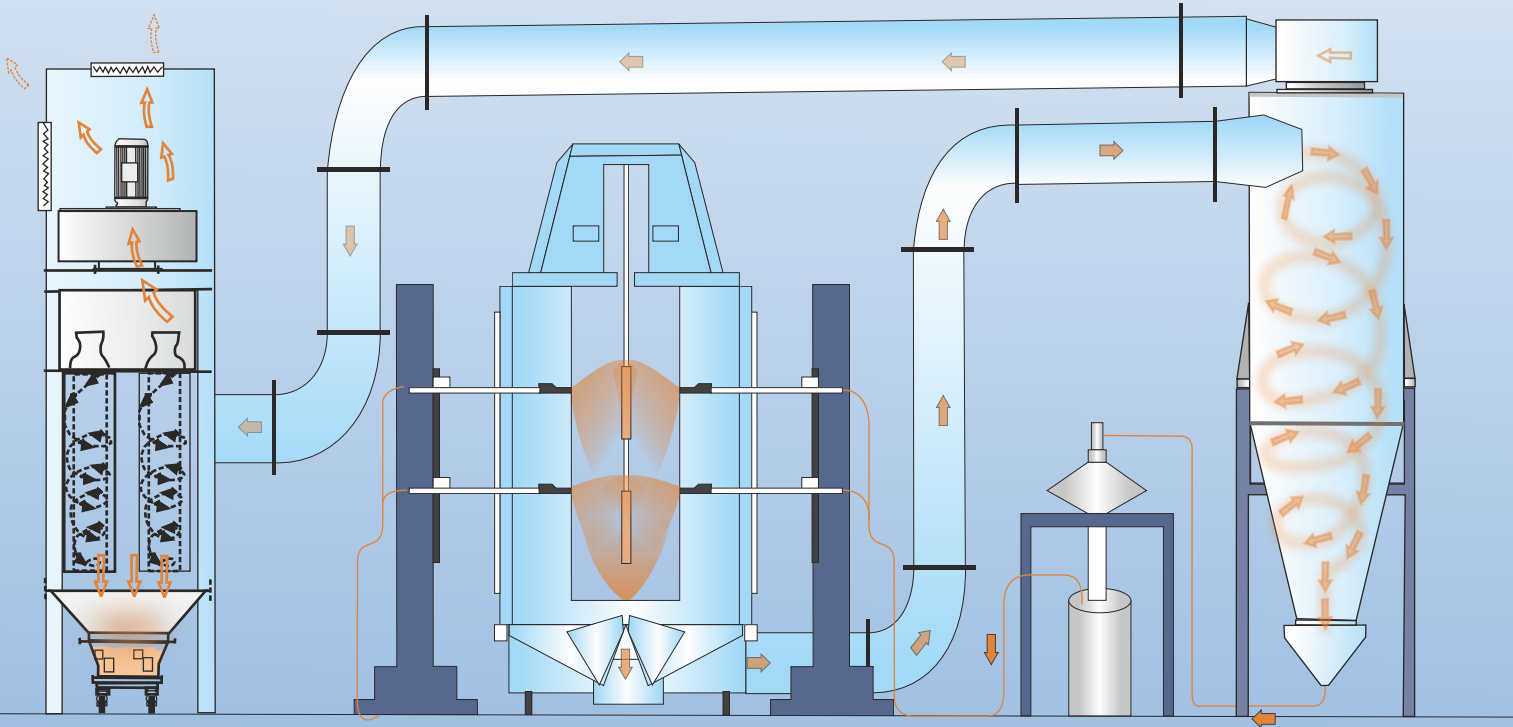

Suitable for big automatic plants where a large quantity of powder is to be sprayed & recovered, and where easy and fast colour change is required.

SUMMARY OF BENEFITS :

- ⊙ First of its kind - superfast color change.
- ⊙ Available in epoxy coated steel / Stainless Steel for “self - cleaning” property.
- ⊙ Can be unclamped from the center for fast, easy & efficient cleaning.
- ⊙ Substantially reduce Powder inventory in coating cycle, when integrated with automatic recycling.
- ⊙ After filter can be purchased as optional item.

Filter System For The 21st Century

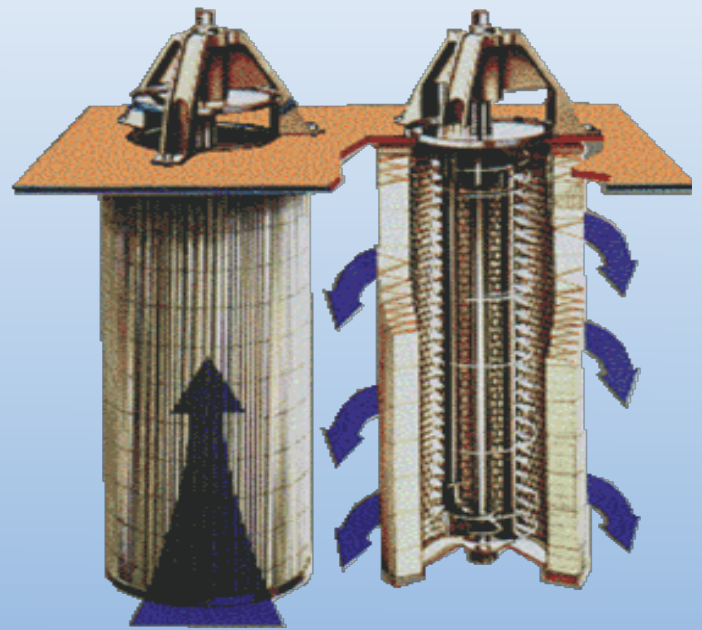

Filter Cartridges - made from melt blown micro fleece offer 99.999% powder recovery efficiencies. A special melt blown PP layer ensures extended service life, much reduced pressure loss and as a result outstanding economy.

Aluminium coated filter media or PTFE coated filter media are also available for critical operations.

ROTATING WING

A special rotating cleaning nozzle system shuts off suction through the filter during the cleaning cycle. Simultaneously compressed air comes out from the small holes along the vertical tube which starts rotating. Deep & thorough cleaning is ensured. Suction automatically commences at the end of cleaning operation.

The cleaning cycle in each filter lasts for a few seconds & is adjustable in the control panel of the equipment.

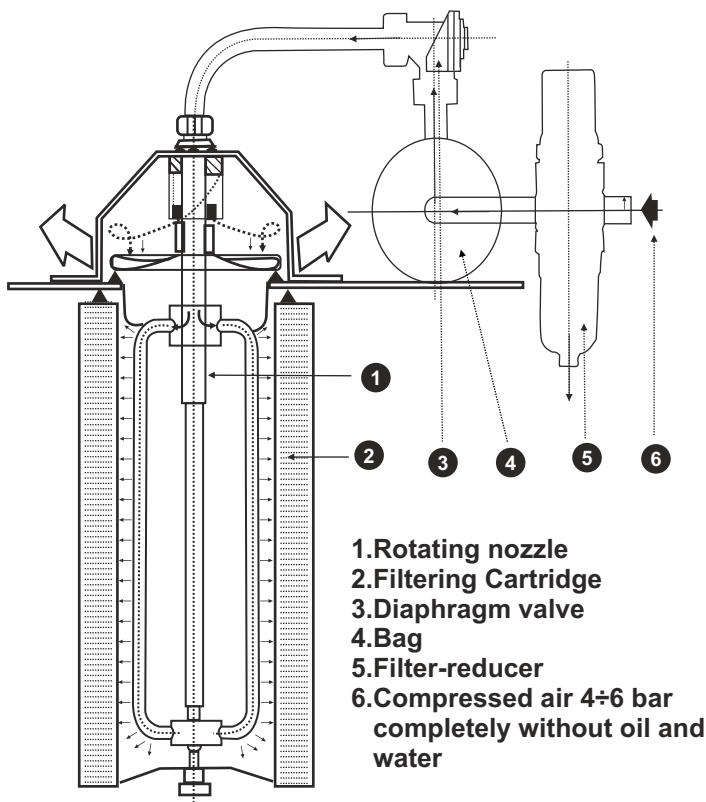

OXY FILTER CARTRIDGE SERIES

• 100% BOOTH RECOVERY • NO MORE ARGUMENTS



OXY FILTER CARTRIDGE SERIES

• 100% BOOTH RECOVERY • NO MORE ARGUMENTS

SUMMARY OF BENEFITS :

- ⊙ Fast colour change with extra colour modules.
- ⊙ Superior cleaning due to rotating wings - Higher cartridge life.
- ⊙ Electricity consumption reduced by 40% when compared to cyclone systems.
- ⊙ Horizontal flow assures uniform film thickness.

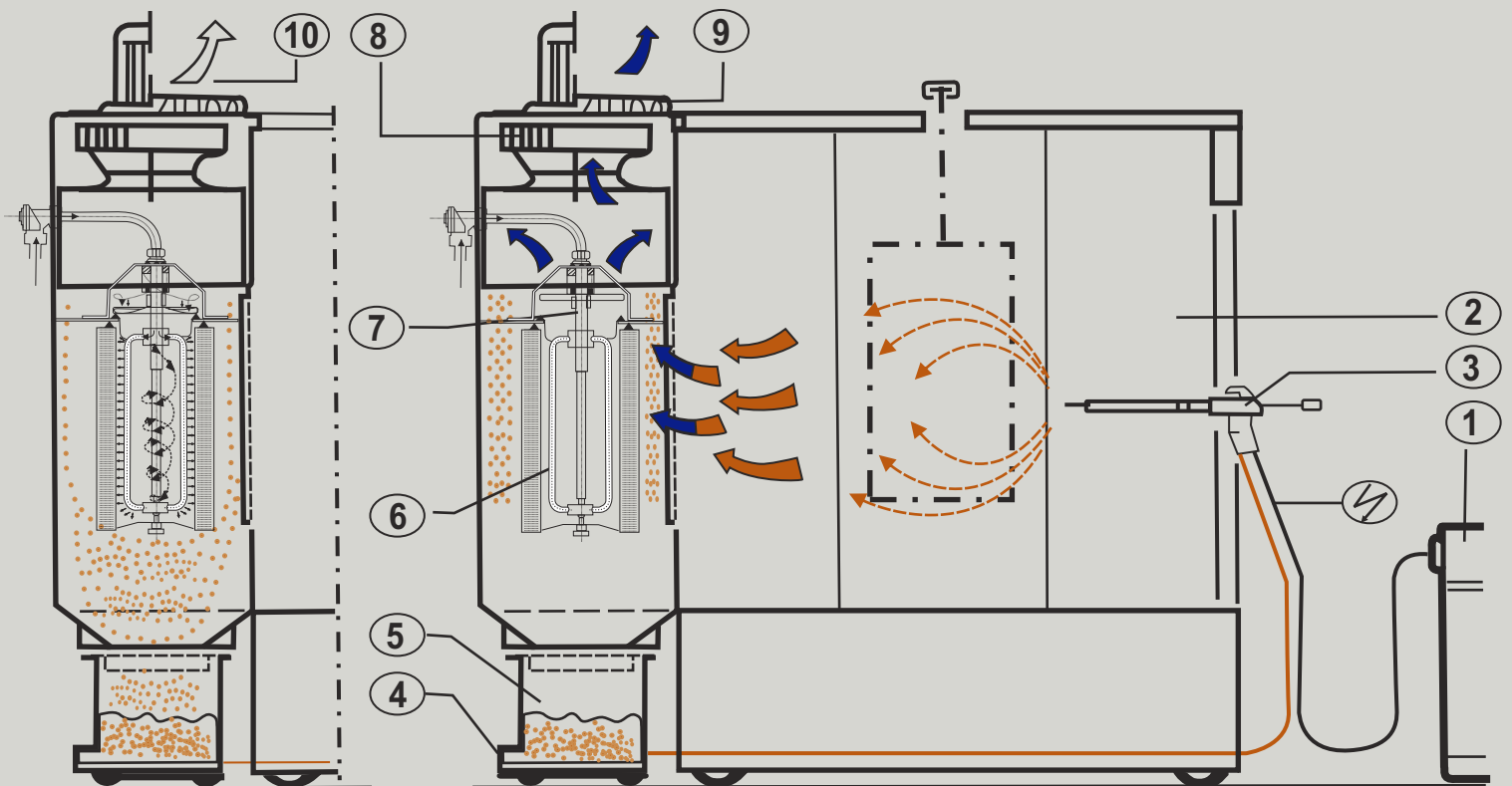
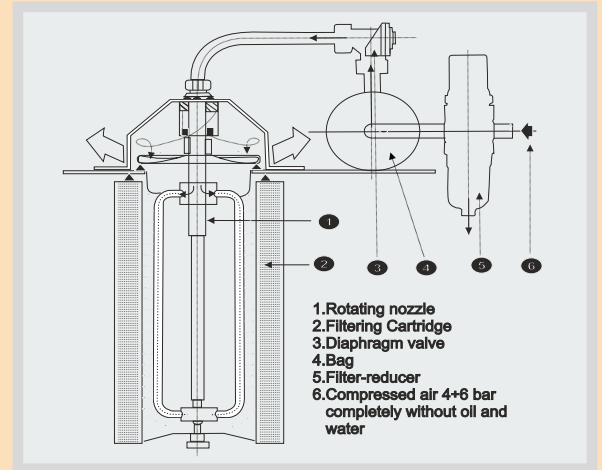
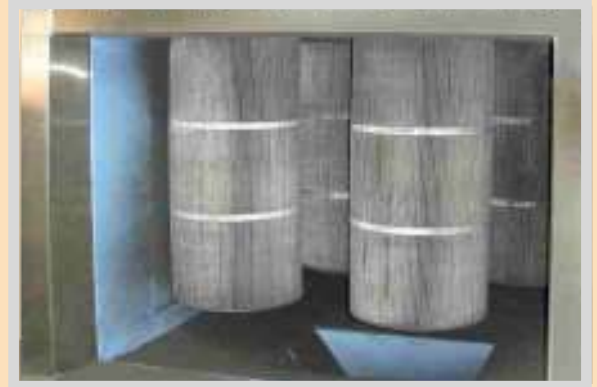

1. CONTROL UNIT
 2. POWDER CABIN

3. SPRAY GUN
 4. FLUIDIZING TILE

5. RECOLLECTION HOPPER
 6. FILTER CARTRIDGE

7. ROTATING WING
 8. EXTRACTOR-SYSTEM

9. POLICE FILTER
 10. CLEAN AIR OUTLET

POWDER MANAGEMENT SYSTEM

BOOST YOUR EFFICIENCY WITH AUTOMATIC RECYCLING OF OVERSPRAY

“ POWDER MANAGEMENT SYSTEM ” is used to automatically transport the recovered powder to the spray hopper via a sieve machine. Fresh powder can also be constantly added to the spray hopper in a desired ratio of recovered and fresh powder.

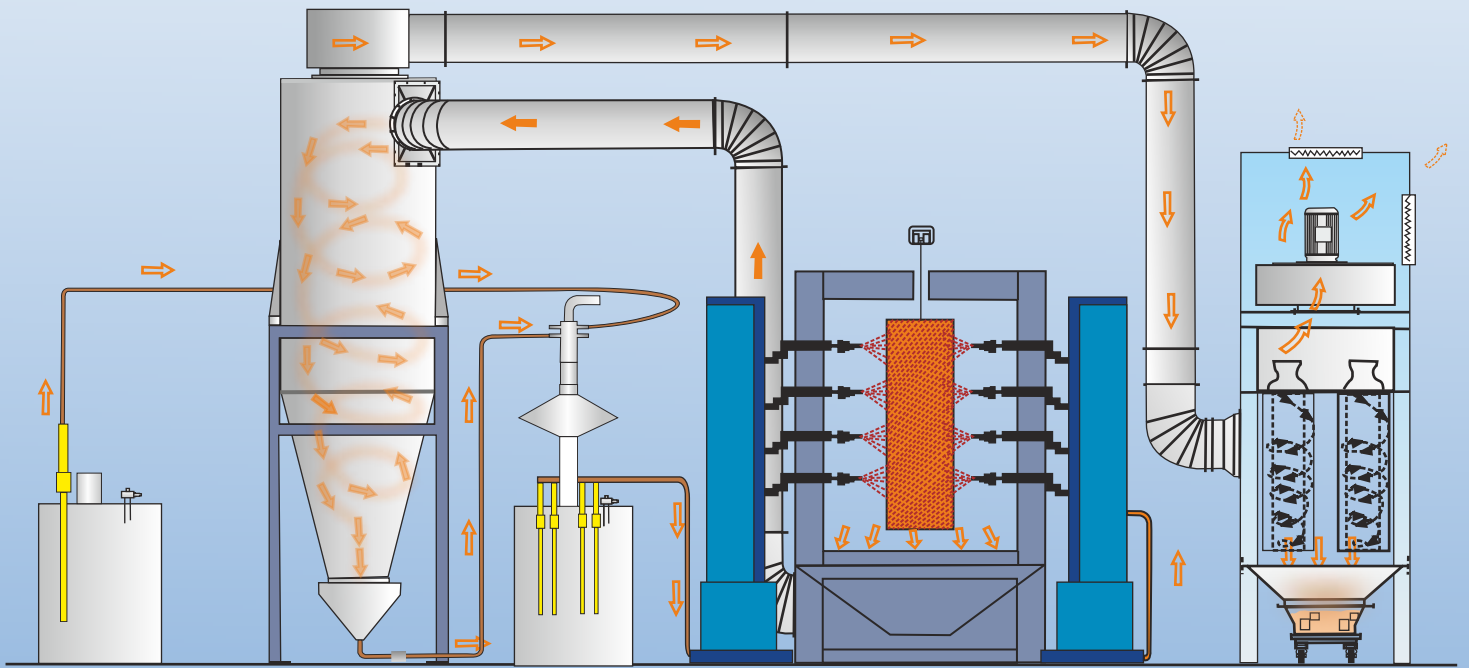

◎ Less powder wastage

◎ Lower production costs

◎ Less on-line inventory

◎ Less labor requirements

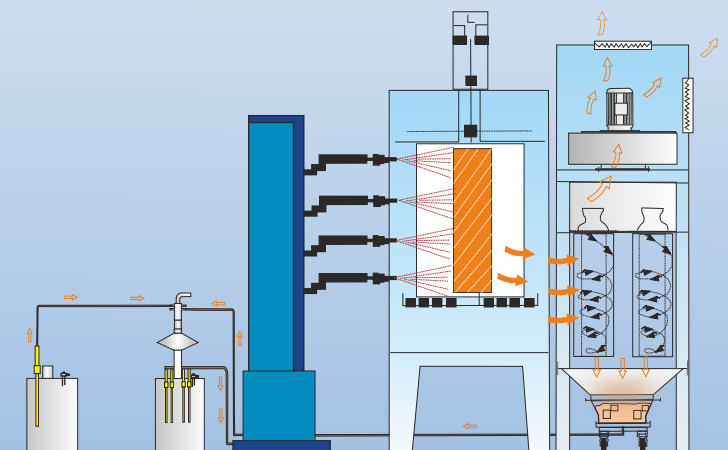
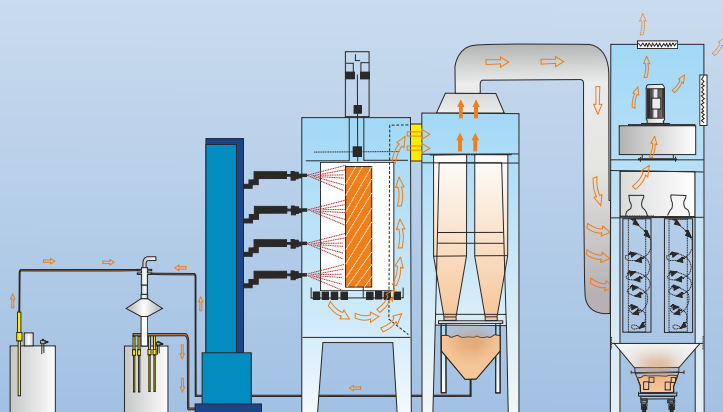

SIEVING MACHINE

Sieving is a crucial process for excellence in powder finishing. It is yet, not given the importance it deserves.

During transportation aggressive vibration causes compacting & lumping of powder in the box. Also powder is hygroscopic it keeps absorbing moisture from compressed air, in the hopper.

Thus powder particles suffer from a “cling together” effect, where 2 or 3 particles which are moist simply remain in “cling together” state even when sprayed.

Such particles receive a poor electrostatic charge. When sprayed they often simply go back to the recovery or they weakly adhere to the job and are dislodged by fresh on coming powder particles. They may go through several spray cycles before actually getting used.

These problems are eliminated by a good sieve machine.

IMPORTANT ADVANTAGES

- Sieving separates lumped powder into distinctly individual particles.
- Sieving separates large dust particles from powder.
- Labor costs are reduced & wastage of manual sieving eliminated.
- The end result – superior finish, higher deposition efficiency, lower operating cost.
- Powder screen mesh – 60/80/100/120. (standard supply – 60/80 mesh)



Electric Stand Alone Siever
(0 to 250 kgs/hr)



Pneumatic Hopper Mounted Siever
(0 to 60 kgs/hr)

EFFICIENCY METER

Worldwide
New

**Instantly Measure
Quality of Gun as well
as Powder.**

- ⊙ Measure Corona tip voltage (0-100 KV DC) - check gun quality.
- ⊙ Measure level of charge in a powder cloud (0-100%) - compare powder quality.
- ⊙ Display +ve or -ve polarity.
- ⊙ Measure ground quality.
- ⊙ Use for all brands of both Manual & Auto Guns.

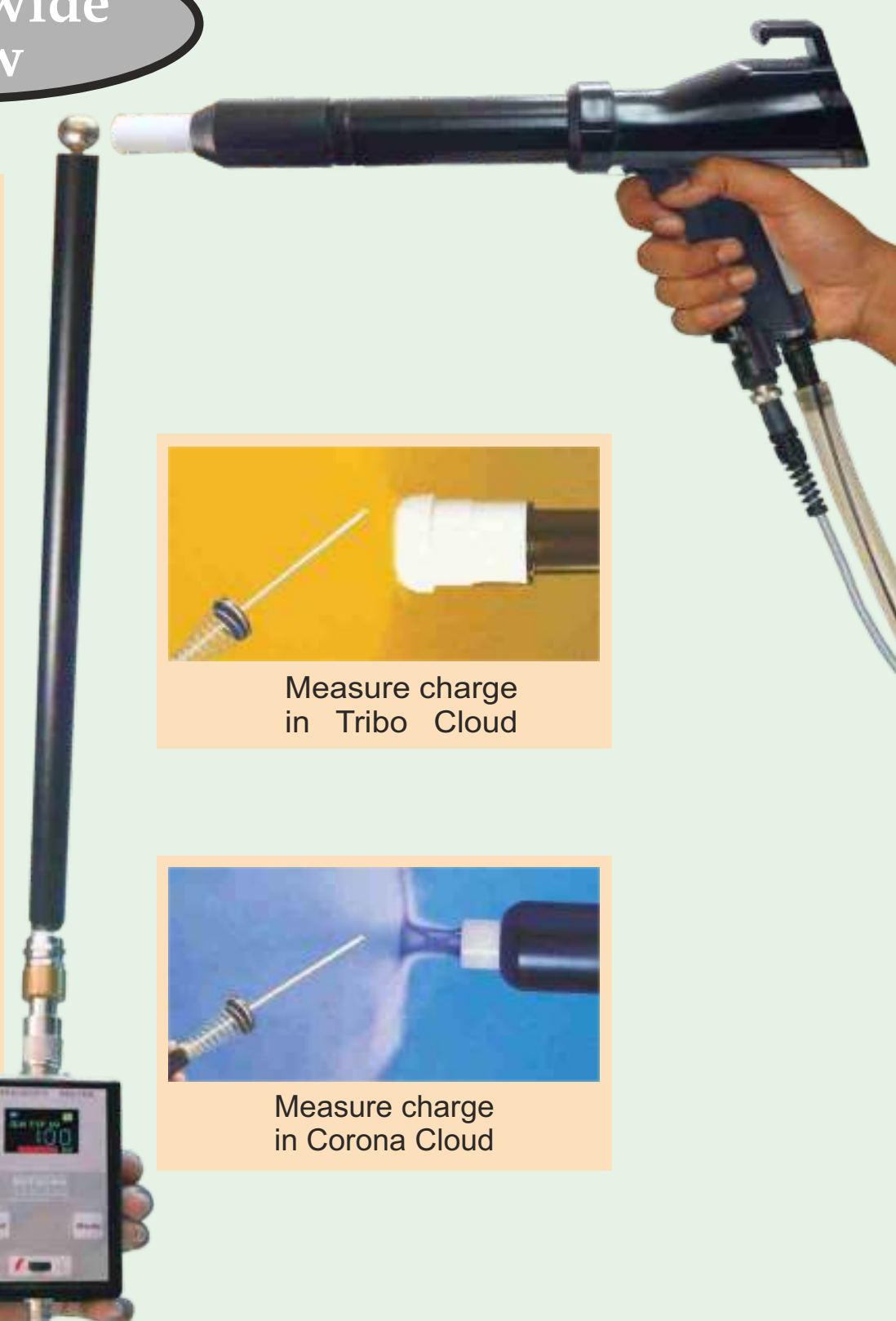

Measure charge
in Tribo Cloud



Measure charge
in Corona Cloud

MITSUBA
SYSTEMS (INDIA) LLP

34/H, Laxmi Ind. Estate, New Link Rd, Andheri (W),
Mumbai 400 053. INDIA.
Tel. : 91-22- 6692 4151/2
Email: sales@powdergun.com
Website: <http://www.powdergun.com>